

Filters

The best partner for value creation
We support the innovations of customers



02



SFI30 & SFT60 Filters

Features

- Trapping fine contamination to maintain system purity
- Gas and liquid filtration
- Standard micron filtering ranges : 0.5, 2, 7, 15, 60 and 90 microns
- Replaceable SS316 sintered elements
- SS316 and Brass body construction
- Choice of reliable S-Lok, NPT & ISO pipe end connections
- Heat Code Traceability

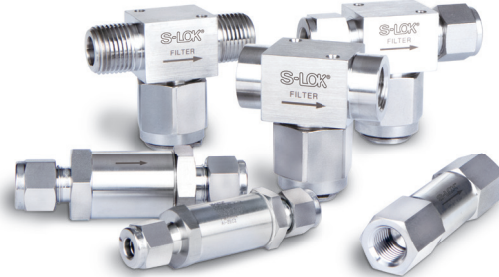

SFI30 IN-Line Filters	SFT60 Tee Filters
<ul style="list-style-type: none"> • In-line filters are applicable where space is limited and elements don't have to be replaced often. • Compact in-line design with large filtration area • Maximum working pressure 3,000 psig @100°F (206 bar @ 38°C) 	<ul style="list-style-type: none"> • Filter Element replaceable with the valve in-line. • Safety union bonnet design for high pressure rating • Optional Bypass for sampling or purging of process fluid. • Maximum working pressure 6,000 psig@100°F (413 bar @38°C)

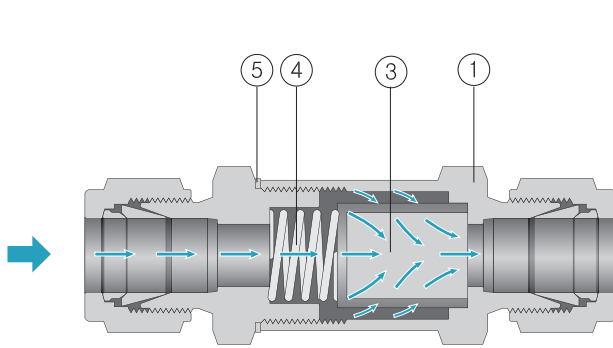

SFI30 In-Line Filters

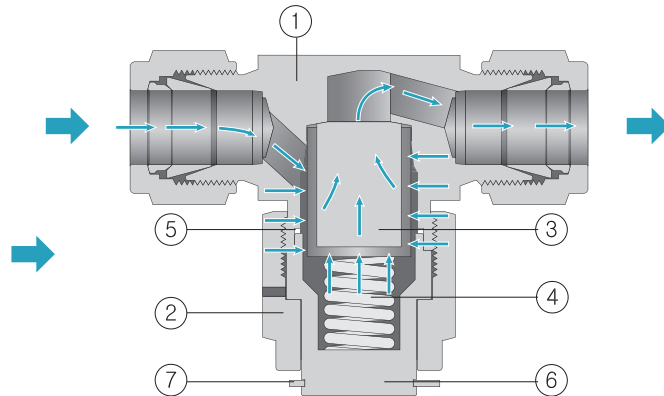

SFT60 Tee Filters

Materials of Construction

Component	SFI30		SFT60	
	Grade / ASTM / Specification			
1 Body	SS316/A276	Brass/B16	SS316/A276	Brass/B16
2 Nut	-	-	SS316/A276	Brass/B16
3 Sintered Element	SS316			
4 Spring	SS302			
5 Gasket	SS316/A240 silver plated			
6 Cap	-	-	SS316/A276	Brass/B16
7 Retainer Ring	-	-	Stainless Steel	

Filtration & Terminology

- **Filter Element** : The component within the Filter which traps media contamination.
- **Filtration Area** : The actual surface area of the filter element available to trap contamination.
- **Micron** : A unit of measure to describe the mean pore diameter of the filter element or the mean particle diameter of media contamination.
 ※ One micron = 0.001mm or 0.00004 inch

SFI30 Series In-Line Filters

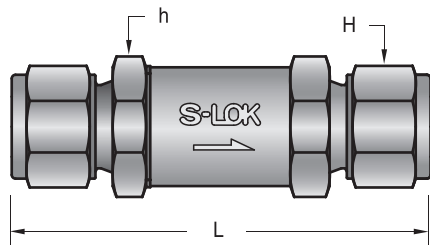

Basic Ordering Number	End Connections Inlet and Outlet	Orifice mm (in.)	Dimensions, mm (in.)			
			L	H	h	
SFI 1	S-2T	1/8 in. S-LOK	59.7(2.35)	11.1(7/16)	14.3(9/16)	
	F-2N	1/8 in. Female NPT	54.9(2.16)	-		
	S-3M	3mm S-LOK	60.5(2.38)	12.0		
SFI 2	S-4T	1/4 in. S-LOK	74.9(2.95)	14.3(9/16)	19.1(3/4)	
	M-4N	1/4 in. Male NPT	68.3(2.69)	-		
	F-4N	1/4 in. Female NPT	72.9(2.87)	-		
	S-6M	6mm S-LOK	75.2(2.96)	14.0		
SFI 3	M-8N	1/2 in. Male NPT	81.3(3.20)	27.0(1-1/16)	25.4(1)	
	S-6T	3/8 in. S-LOK	81.5(3.21)			
SFI 4	S-8T	1/2 in. S-LOK	10.3(0.41)	88.6(3.49)	22.2(7/8)	25.4(1)

All dimensions shown are for reference only and are subject to change.
Dimensions with S-Lok nuts are in finger-tight position.

Flow Capacities

Filter Series	Element Nominal Pore Micron μm	Inlet Pressure, [®] psig (bar)			Pressure Drop, psi (bar)		
		5(0.34)	10(0.68)	15(1.0)	10(0.68)	50(3.4)	100(6.8)
		Air Flow, std ft ³ /min (std L/min)			Water Flow, U.S. gal/min (L/min)		
SFI 1 Series	0.5	0.04 (1.1)	0.06 (1.7)	0.12 (3.4)	0.01 (0.03)	0.04 (0.15)	0.12 (0.45)
	2	0.20 (5.6)	0.40 (11)	0.60 (17)	0.08 (0.30)	0.24 (0.91)	0.40 (1.5)
	7	0.50 (14)	0.90 (25)	1.2 (34)	0.10 (0.37)	0.30 (1.1)	0.48 (1.8)
	15	0.80 (22)	1.3 (36)	1.5 (42)	0.12 (0.45)	0.36 (1.3)	0.58 (2.1)
	60	1.7 (48)	2.2 (62)	2.4 (68)	0.15 (0.56)	0.50 (1.8)	0.70 (2.6)
SFI 2 Series	0.5	0.12 (3.4)	0.26 (7.3)	0.48 (13)	0.04 (0.15)	0.17 (0.64)	0.29 (1.0)
	2	0.60 (17)	1.4 (39)	2.3 (65)	0.24 (0.90)	0.86 (3.2)	1.3 (4.9)
	7	1.4 (39)	2.9 (82)	4.7 (130)	0.40 (1.5)	1.3 (4.9)	2.0 (7.5)
	15	1.2 (34)	2.9 (82)	4.7 (130)	0.50 (1.8)	1.3 (4.9)	2.1 (7.9)
	60	3.1 (87)	5.9 (160)	8.5 (240)	0.90 (3.4)	3.3 (12)	4.6 (17)
SFI 3 Series	0.5	0.36 (10)	0.86 (24)	1.6 (45)	0.09 (0.34)	0.40 (1.5)	0.76 (2.8)
	2	1.4 (39)	2.8 (79)	4.0 (110)	0.26 (0.98)	1.1 (4.1)	1.6 (6.0)
	7	1.8 (51)	4.2 (119)	6.8 (190)	0.64 (2.4)	2.2 (8.3)	3.5 (13)
SFI 4 Series	15	1.8 (51)	4.9 (130)	7.9 (220)	0.84 (3.1)	2.6 (9.8)	4.1 (15)
	60	5.1 (140)	10 (280)	15 (420)	2.0 (7.5)	6.7 (25)	10 (37)
	90	6.1 (170)	11 (310)	16 (450)	2.3 (8.7)	7.6 (28)	11 (41)

Element Replacement

- The sintered elements don't permit the contaminants in the gas and liquid to pass through the elements when they are bigger than the pore size of micron.
- Contaminants are trapped by element pores and it results in pressure buildup.
- Contamination comes earlier when flow volume is high and media is not clean.
- The filtering elements need to be replaced for the pressure drop as well as its system purity.
 - ※ Note : Clean filter valve components whenever the element is replaced.

Sintered Elements

- Stainless steel 316 sintered
- High heat resistance and thermal stability up to 1,500 °F (815 °C).
- High permeability with low-pressure drop.
- Shape-stability with self-supporting structural elements.
- Suitable for compression, vibration, and high impulse pressure.
- Precise filtration due to the exact and uniform pore size and distribution.
- Chemical resistance against acids and caustic solutions in various ranges of pH.

Element Designator	Nominal Pore Size, μm	Pore Size Range, μm	Element Porosity	Cv Factor	Max. Pressure Differential Across Clean Filters at 70°F (21 °C)
05	0.5	0.5-2	17%	0.046	1160 psig (80 bar)
2	2	1-4	22%	0.056	
7	7	5-10	27%	0.12	
15	15	11-25	36%	0.13	
60	60	50-75	44%	0.38	
90	90	75-110	45%	0.50	

Pressure-Temperature Ratings

Filter Series	Pressure Rating @100 °F (38 °C) psig (bar)		Temperature Rating °F (°C)		Filtration Area with Sintered Element inch ² (mm ²)
	SS316	Brass	SS316	Brass	
SFI 1	3000(206)	1000(68.9)	-20 to 900 (-28 to 482)	-20 to 300 (-28 to 148)	0.55(350)
SFI 2					1.30(830)
SFI 3, SFI 4	2500(172)				1.98(1280)

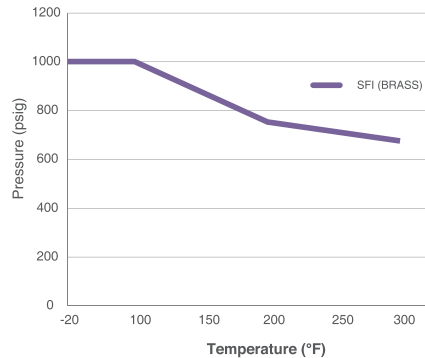
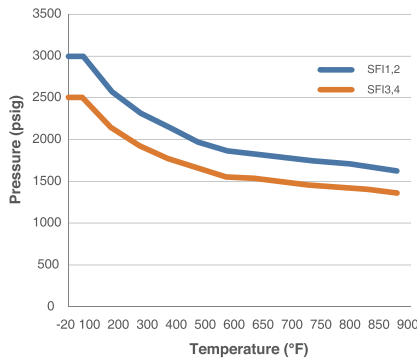

Ordering Information

Select desired basic ordering number, element designator, option and body material listed below.



Series Designator	Sintered Element		Body Material
	Element Designator	Nominal Micron	
Basic Ordering Number	05	0.5	• S6 : SS316 • BS : Brass
	2	2	
	7	7	
	15	15	
	60	60	
	90	90	
	NE	Filter with no element	

SFT60 Series Tee Filters

Ordering Information and Dimensions

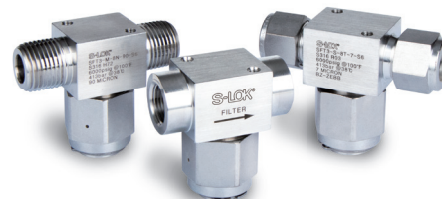
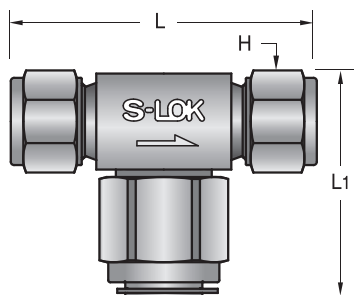

Basic Ordering Number		End Connections Inlet and Outlet	Orifice inch (mm)	Dimensions mm (in.)		
				L	L ₁	H
SFT 1	F-2N	1/8 in. Female NPT	0.17(4.4)	50.8(2.00)	47.5 (1.87)	-
	S-2T	1/8 in. S-LOK	0.09(2.3)	27.7(2.27)		7/16
	S-4T	1/4 S-LOK	0.17 (4.4)	62.7(2.47)		9/16
	M-4N	1/4 Male NPT		54.1(2.13)		-
	F-4N	1/4 Female NPT		54.1(2.13)		-
	S-6M	6mm S-LOK		62.5(2.46)		14mm
SFT 2	S-6T	3/8 S-LOK	0.21 (5.4)	72.1(2.84)	56 (2.20)	11/16
	S-8M	8mm S-LOK	72.1(2.84)	16mm		
SFT 3	M-6N	3/8 Male NPT	0.25 (6.4)	60.5(2.38)	56 (2.20)	-
	S-10M	10mm S-LOK		72.6(2.86)		19mm
	S-12M	12mm s-lok		77.2(3.04)		22mm
	S-8T	1/2 S-LOK		77.2(3.04)		7/8
	M-8N	1/2in. Male NPT		68.9(2.75)		-

All dimensions shown are for reference only and are subject to change.

Dimensions with S-Lok nuts are in finger-tight position.

Flow Capacities

Filter Series	Element Nominal Pore Micron μm	Inlet Pressure, [®] psig (bar)			Pressure Drop, psi (bar)		
		5(0.34)	10(0.68)	15(1.0)	10(0.68)	50(3.4)	100(6.8)
		Air Flow, std ft ³ /min (std L/min)			Water Flow, U.S. gal/min (L/min)		
SFT 1 Series	0.5	0.04 (1.1)	0.06 (1.7)	0.12 (3.4)	0.04 (0.15)	0.17 (0.64)	0.29 (1.0)
	2	0.20 (5.6)	0.40 (11)	0.60 (17)	0.08 (0.30)	0.24 (0.91)	0.40 (1.5)
	7	0.50 (14)	0.90 (25)	1.2 (34)	0.10 (0.37)	0.30 (1.1)	0.48 (1.8)
	15	0.80 (22)	1.3 (36)	1.5 (42)	0.12 (0.45)	0.36 (1.3)	0.58 (2.1)
	60	1.7 (48)	2.2 (62)	2.4 (68)	0.15 (0.56)	0.50 (1.8)	0.70 (2.6)
SFT 2 Series	90	1.8 (51)	2.2 (62)	2.6 (73)	0.20 (0.75)	0.50 (1.8)	0.60 (2.2)
	0.5	0.12 (3.4)	0.26 (7.3)	0.48 (13)	0.04 (0.15)	0.17 (0.64)	0.29 (1.0)
	2	0.60 (17)	1.4 (39)	2.3 (65)	0.24 (0.90)	0.86 (3.2)	1.3 (4.9)
	7	1.4 (39)	2.9 (82)	4.7 (130)	0.40 (1.5)	1.3 (4.9)	2.0 (7.5)
	15	1.2 (34)	2.9 (82)	4.7 (130)	0.50 (1.8)	1.3 (4.9)	2.1 (7.9)
SFT 3 Series	60	3.1 (87)	5.9 (160)	8.5 (240)	0.80 (3.0)	2.7 (10)	3.9 (14)
	90	4.1 (110)	7.5 (210)	10 (280)	1.1 (4.1)	3.4 (12)	4.9 (18)
	0.5	0.36 (10)	0.86 (24)	1.6 (45)	0.09 (0.34)	0.40 (1.5)	0.76 (2.8)
	2	1.4 (39)	2.8 (79)	4.0 (110)	0.26 (0.98)	1.1 (4.1)	1.6 (6.0)
	7	1.8 (51)	4.2 (119)	6.8 (190)	0.64 (2.4)	2.2 (8.3)	3.5 (13)
SFT 3 Series	15	1.8 (51)	4.9 (130)	7.9 (220)	0.84 (3.1)	2.6 (9.8)	4.1 (15)
	60	5.1 (140)	10 (280)	15 (420)	1.5 (5.6)	4.8 (18)	6.7 (25)
	90	6.1 (170)	11 (310)	16 (450)	1.7 (6.4)	5.5 (20)	7.6 (28)

Pressure-Temperature Ratings

Filter Series	Pressure Rating @100°F (38°C) psig (bar)		Temperature Rating °F (°C)		Filtration Area with Sintered Element inch ² (mm ²)
	SS316	Brass	SS316	Brass	
SFT1, SFT2	6,000(413)	2,000(137)	-20 to 900 (-28 to 482)	-20 to 300 (-28 to 148)	1.3(830)
SFT3					1.98(1280)

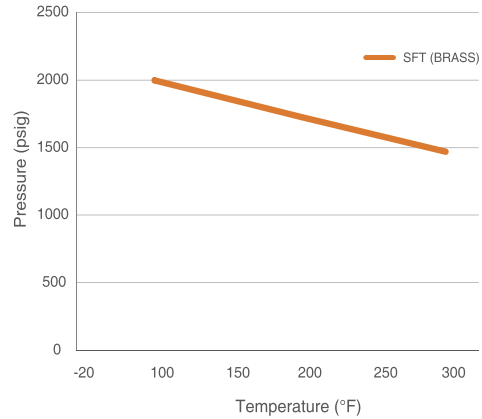
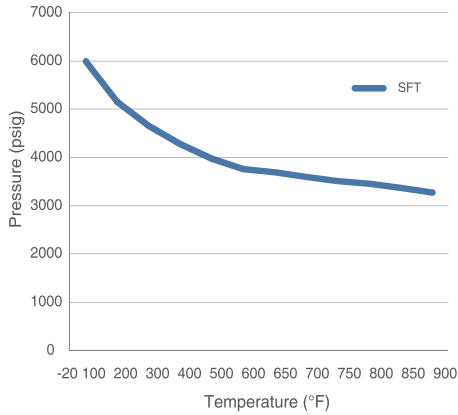

SFT Series Tee Filter CNG / NGV Certifications

Certificates	ECE R110	ANSI NGV 3.1 - 2012	ISO 15500
Certificate No.	110R-010334	126841AUT15	126841MECH104
Classification	Class 0	Manual valve	Manual valve
Temperature	-40 to 120°C (-40 to 248°F)	-40 to 120°C (-40 to 248°F)	-40 to 120°C (-40 to 248°F)
Working Pressure	260 bar @ 120°C	248 bar @ 120°C	260 bar @ 120°C

Ordering Information

Select desired basic ordering number, element designator, option and body material listed below.



Series Designator	Sintered Element		By-pass	Body Material
	Element Designator	Nominal Micron		
Basic Ordering Number	05	0.5	<ul style="list-style-type: none"> Nil : No By-pass option BF2N : 1/8 in. Female NPT BF4N : 1/4 in. Female NPT 	<ul style="list-style-type: none"> S6 : SS316 BS : Brass
	2	2		
	7	7		
	15	15		
	60	60		
	90	90		
	NE	Filter with no element		